



Allegare ai testi di pag.3 e 4 • This sheet to be with texts on pages 5 and 6
 Fiche à associer aux textes des pages 7 et 8 • Dieses Datenblatt muß vom Text von S.9-10
 Ficha a unirse a textos pág.11 y 12 • Esta ficha com textos pág.13 e 14

FlexaThema
 SQUARE



ELT13-15

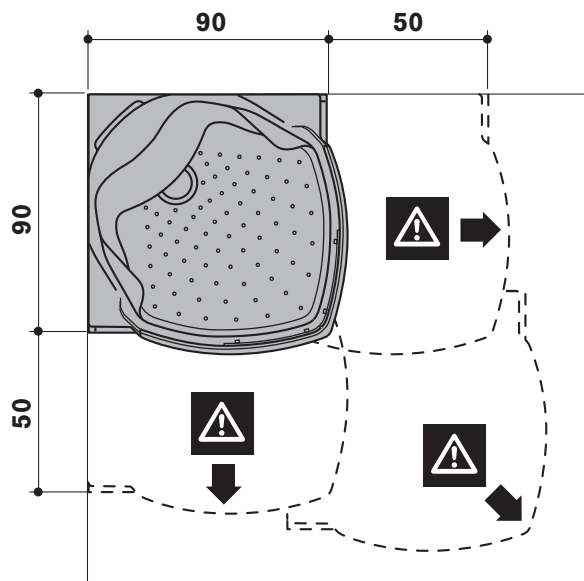
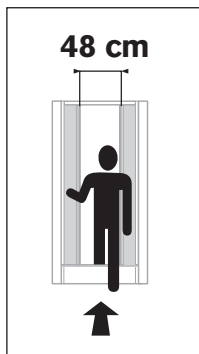
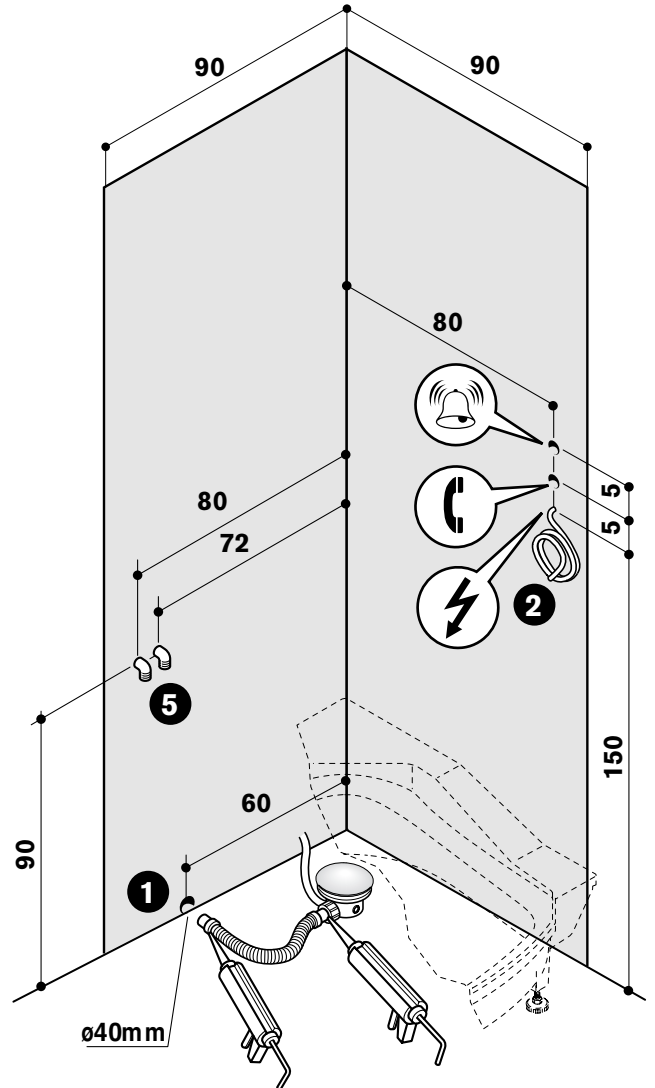
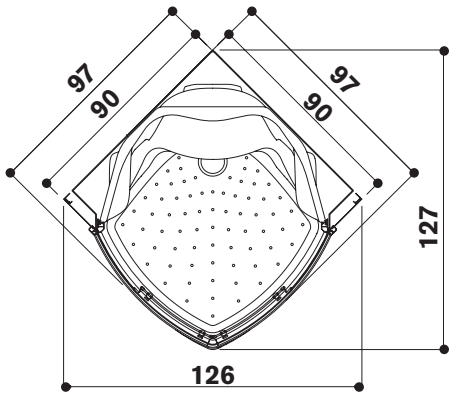
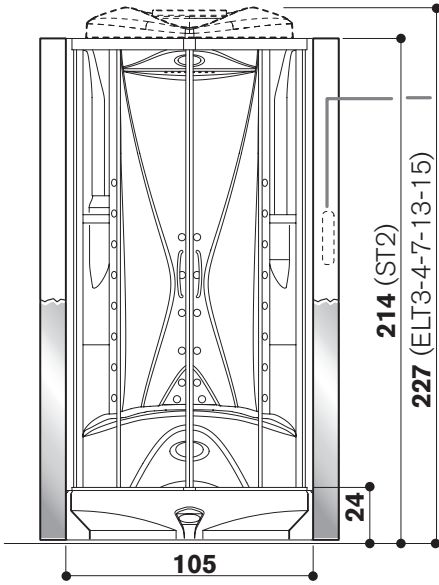

**ZONA LIBERA • ACCESS SPACE
 BANDE LIBRE • FREIRAUM
 ESPACIO LIBRE • ESPAÇO LIVRE**





CARATTERISTICHE IDRAULICHE • HYDRAULIC SPECIFICATIONS • CARACTERISTIQUES HYDRAULIQUES

HYDRAULIK-ANGABEN • CARACTERISTICAS HIDRAULICAS • CARACTERÍSTICAS HIDRÁULICAS

	ST2	ELT3	ELT4	ELT7	ELT13	ELT15
PRESSIONE DI ESERCIZIO • OPERATING PRESSURE • PRESSION DE SERVICE BETRIEBSDRUCK • PRESIÓN DE FUNCION. • PRESSÃO DE FUNCION.....bar	*	*	*	*	*	*
PRESSIONE OTTIMALE • OPTIMUM PRESSURE • PRESSION OPTIMAL OPTIMALER WASSERDRUCK • PRESIÓN ÓPTIMAL • PRESSÃO OPTIMAL.....bar	2+3	2+3	2+3	2+3	2+3	2+3
CONSUMO D'ACQUA • WATER CAPACITY • CONSOMMATION D'EAU WASSERVERBRAUCH • CONSUMO DE AGUA • CONSUMO DE ÁGUA.....l/min (MAX)	14 ⁽¹⁾	13 ⁽²⁾	13 ⁽²⁾	13 ⁽²⁾	13 ⁽²⁾	13 ⁽²⁾
BOCCHETTE IDRO • WHIRLPOOL FITTINGS • BUSES HYDROMASSAGE ANZAHL MASSAGEDÜSEN • BOQUILLAS HIDROMASAJE • JACTOS DE HIDROMASSAGEM	8 + 4	16 + 4	16 + 8	16 + 8	16 + 8	16 + 8
COLLEGAMENTI • CONNECTIONS • RACCORDEMENTS ANSCHLÜSSE • CONEXIONES • CONEXÃO						
ACQUA CALDA/FREDDA • HOT/COLD WATER • EAU CHAUDE/FROIDE KALT/WARMWASSER • AGUA CALIENTE/FRIA • ÁGUA QUENTE/FRIA.....Ø	1/2"	1/2"	1/2"	1/2"	1/2"	1/2"
SCARICO A PARETE • WALL DRAINAGE • ÉCOULEMENT AU SOL ABFLUSSROHR AM BODEN • DESAGUADERO EN SUELO • DESCARGA NO PAVIMENTO.....Ø	40 mm	40 mm	40 mm	40 mm	40 mm	40 mm

(*) min 1,5 max 5 (min 21 psi max 70 psi)

(1) idrogetti (a 2,5 bar) • hydro-nozzles (at 2,5 bar) • buses hydro (à 2,5 bar) • Massagedüsen (hat 2,5 bar) • boquillas de hidro (a 2,5 bar) • bocas hidro (a 2,5 bar)

(2) rotodoccia (a 2,5 bar) • rotoshower (at 2,5 bar) • douche tournant (à 2,5 bar) • Rotordusche (hat 2,5 bar) • rotoducha (a 2,5 bar) • rotoduche (a 2,5 bar)

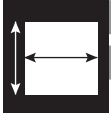

CARATTERISTICHE DIMENSIONALI • WEIGHT AND DIMENSIONS • DIMENSIONS & POIDS

MASSE UND GEWICHTE • CARACTERISTICAS DIMENSIONALES • DIMENSÕES E PESOS

	ST2	ELT3	ELT4	ELT7	ELT13	ELT15
LxWxH cm	90/97x90/97x214	90/97x90/97x227	90/97x90/97x227	90/97x90/97x227	90/97x90/97x227	90/97x90/97x227
PESO NETTO • NET WEIGHT • POIDS NET • NETTOGEW. • NETO • LÍQUIDO~ kg	115	126	126	126	128	128
PESO DI SPEDIZIONE • SHIPPING WEIGHT • POIDS À L'EXPÉDITION VERSANDGEWICHT • PESO DE EXPEDICIÓN • PESO DE EXPEDIÇÃO.....~ kg	180	191	191	191	193	193
VOLUME DI SPEDIZIONE • SHIPPING VOLUME • VOLUME À L'EXPÉDITION VERSANDVOLUMEN • VOLUMEN DE EXPEDICIÓN • VOLUME DE EXPEDIÇÃO.....~ m ³	3,27	3,27	3,27	3,27	3,27	3,27
IMBALLO • PACKAGE • EMBALLAGE • VERPACKUNG • EMBAL. • EMBAL.....cm	A+B+C ^(x)	A+B+C ^(x)	A+B+C ^(x)	A+B+C ^(x)	A+B+C ^(x)	A+B+C ^(x)

(x) A: parete • panele • panneau • Paneel • parede • pareda: 206x97x103 - kg 44/81 (ST2) • kg 50/87 (ELT3, 4, 7) • kg 52/89 (ELT13, 15)

B: piatto doccia • shower tray • plateau de douche • Duschwanne • plato de ducha • fundo do ducha: 109x107x38 - kg 15/21 (ST2) • kg 20/26 (ELT3, 4, 7, 13, 15)

C: cristalli • glasses • vitres • Gläse • cristales • cristais: 222x81x43 - kg 56/78



CARATTERISTICHE ELETTRICHE • ELECTRIC SPECIFICATIONS • CARACTERISTIQUES ELECTRIQUES

ELEKTRO-ANGABEN • CARACTERISTICAS ELECTRICAS • CARACTERÍSTICAS ELÉCTRICAS

	ST2	ELT3	ELT4	ELT7	ELT13	ELT15
VOLT.....V	-	220/240	220/240	220/240	220/240	220/240
HERTZ.....Hz	-	50	50	50	50	50
AMPÈRE (BAGNO TURCO) • (STEAM BATH) • (HAMMAM) • (DAMPFBAD) • (BAÑO TURCO) • (BANHO TURCO).....A	-	11 ^(k)	11 ^(k)	11 ^(k)	11 ^(k)	11 ^(k)
KW (BAGNO TURCO) • (STEAM BATH) • (BAIN TURC) • (DAMPFBAD) • (BAÑO TURCO) • (BANHO TURCO).....kW	-	2,5 ^{(j)(k)}	2,5 ^{(j)(k)}	2,5 ^{(j)(k)}	2,5 ^{(j)(k)}	2,5 ^{(j)(k)}

(j) potenza assorbita • power absorption • puissance absorbée • Leistungsaufnahme • potencia absorbida • potência absorvida **MAX 2,5 kW**

(k) a 230 V • a 230 V • à 230 V • hat 230 V • a 230 V • a 230 V