

PFG2 - FG2

- D** Montageanleitung
Duschinsel
- I** Istruzioni di montaggio
Isola doccia
- NL** Montage-instructie
Enkele inloop
- GB** Assembling instructions
Shower-Island
- F** Instructions de montage
Douche-île
- E** Instrucciones para el montaje
Isla de Ducha
- PL** Instrukcja montażu
wyspa natryskowa

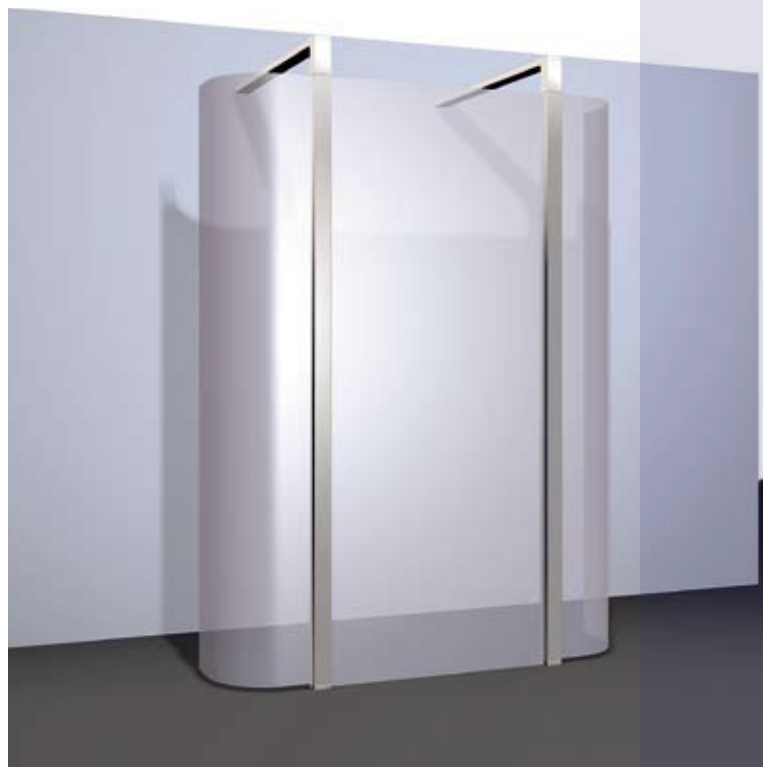

PFG2 - FG2

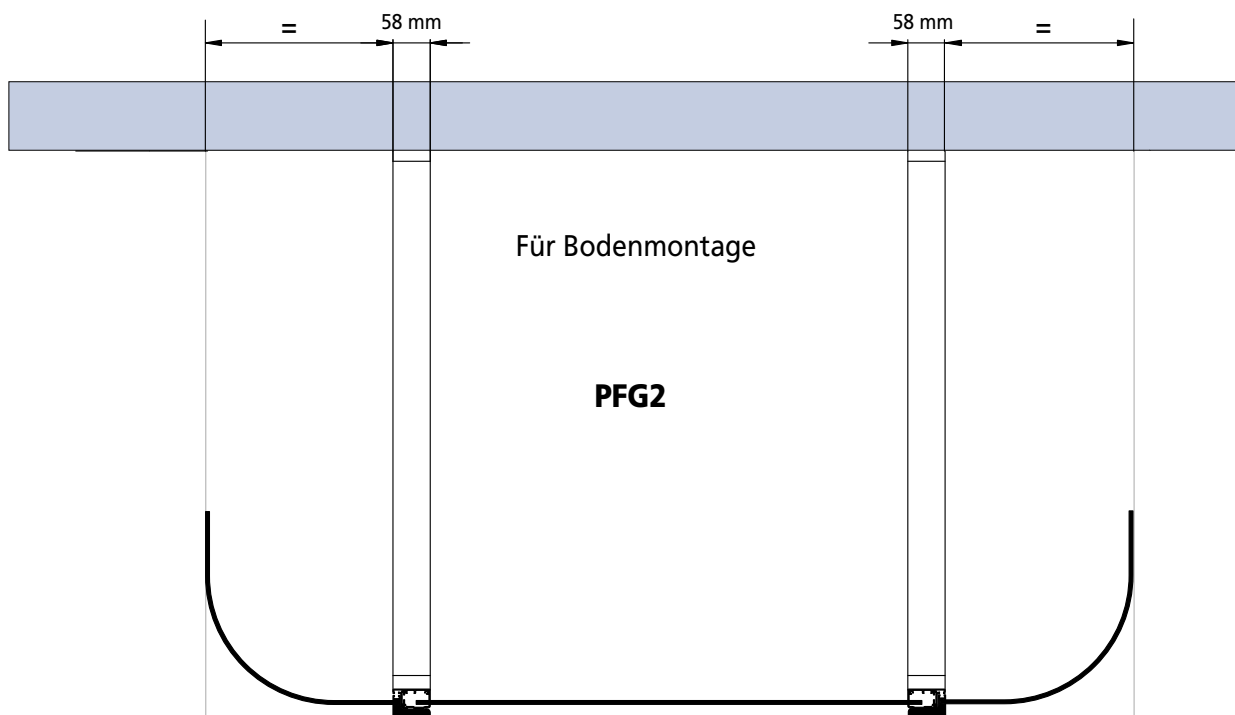
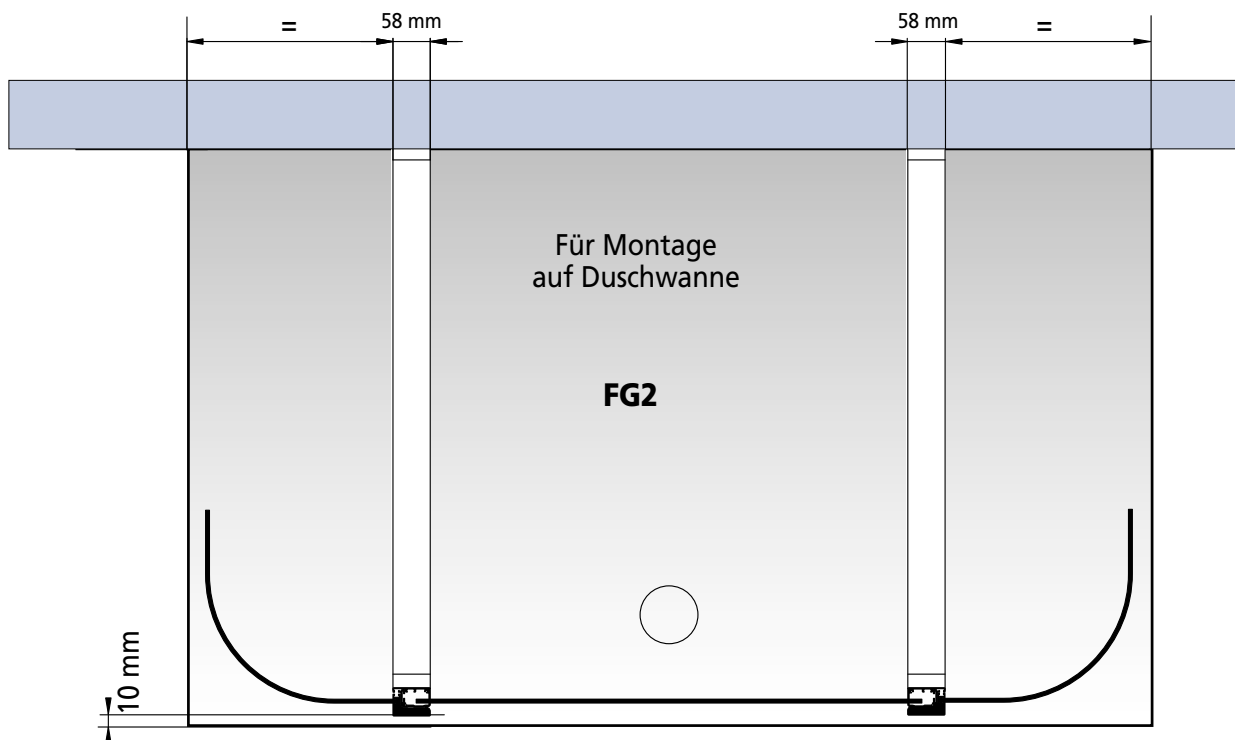



1

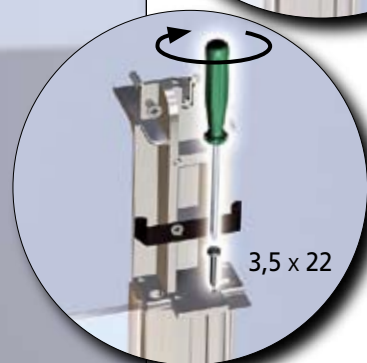
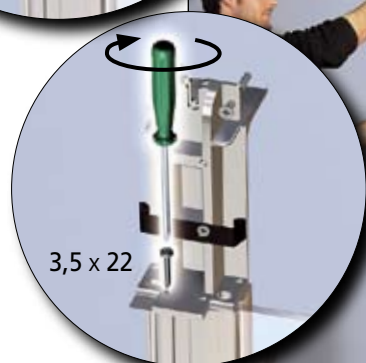
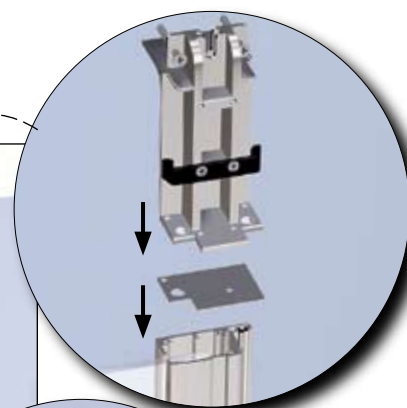
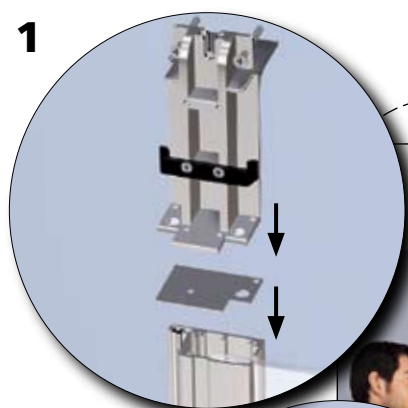

2

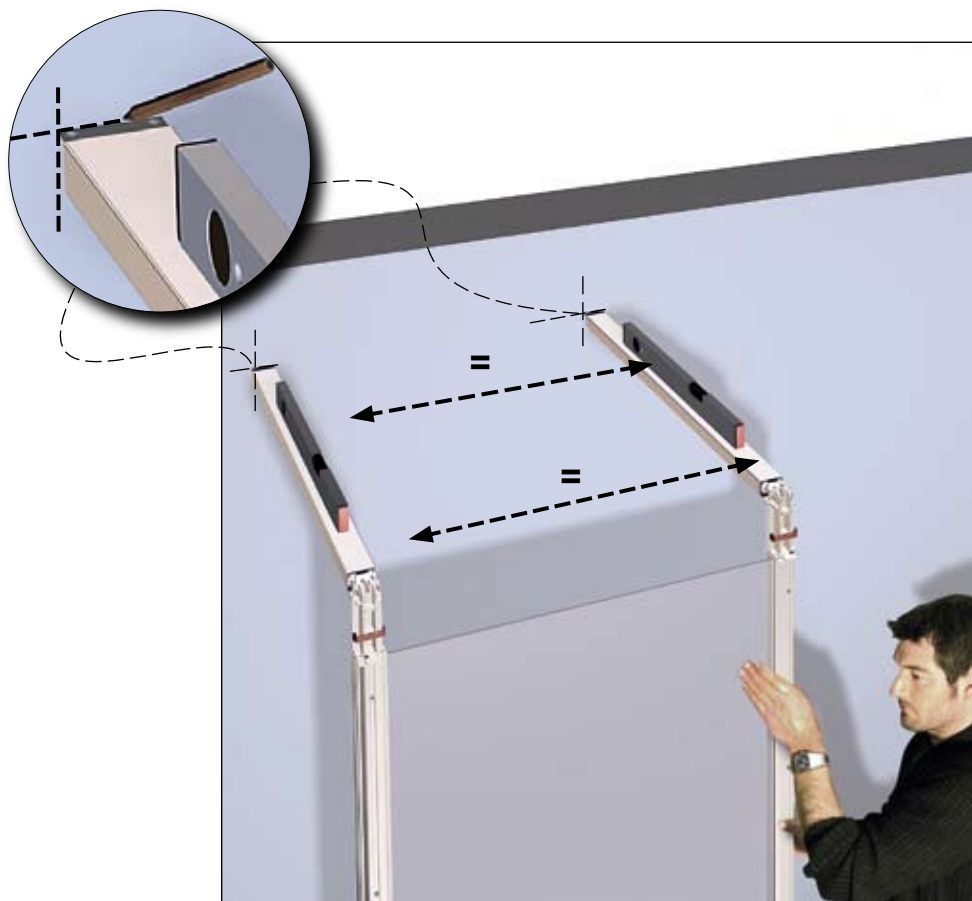

3

1

2

3

4

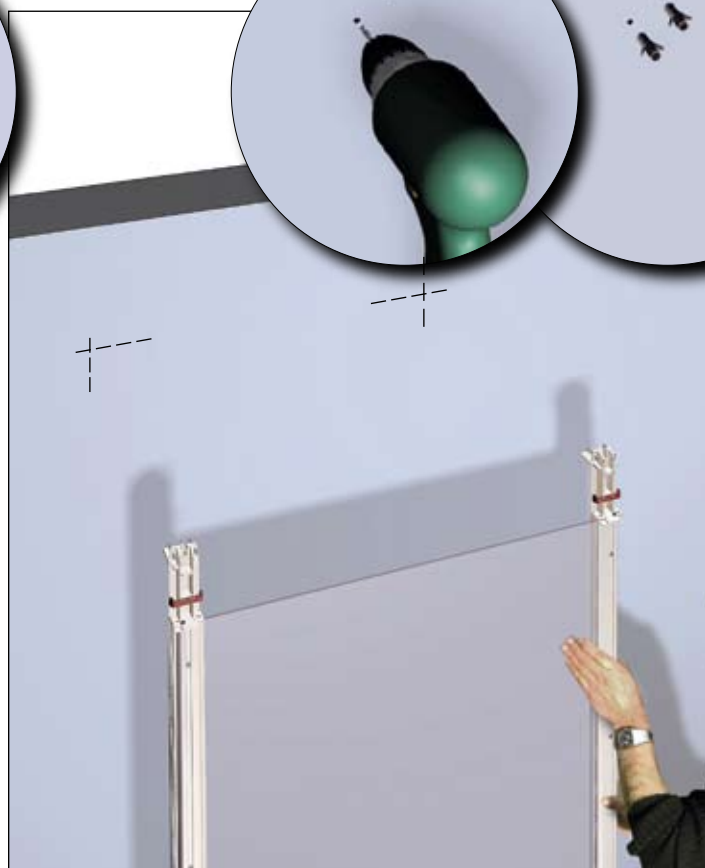
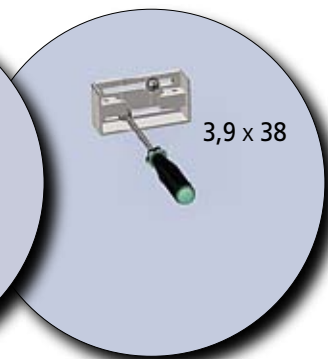
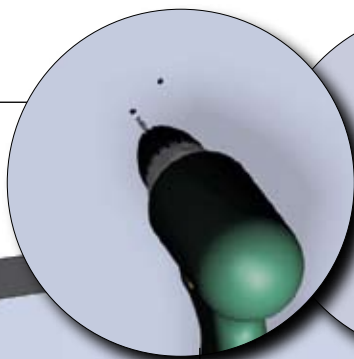
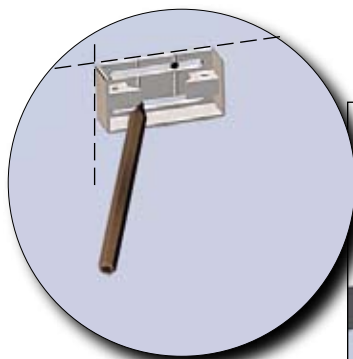

4

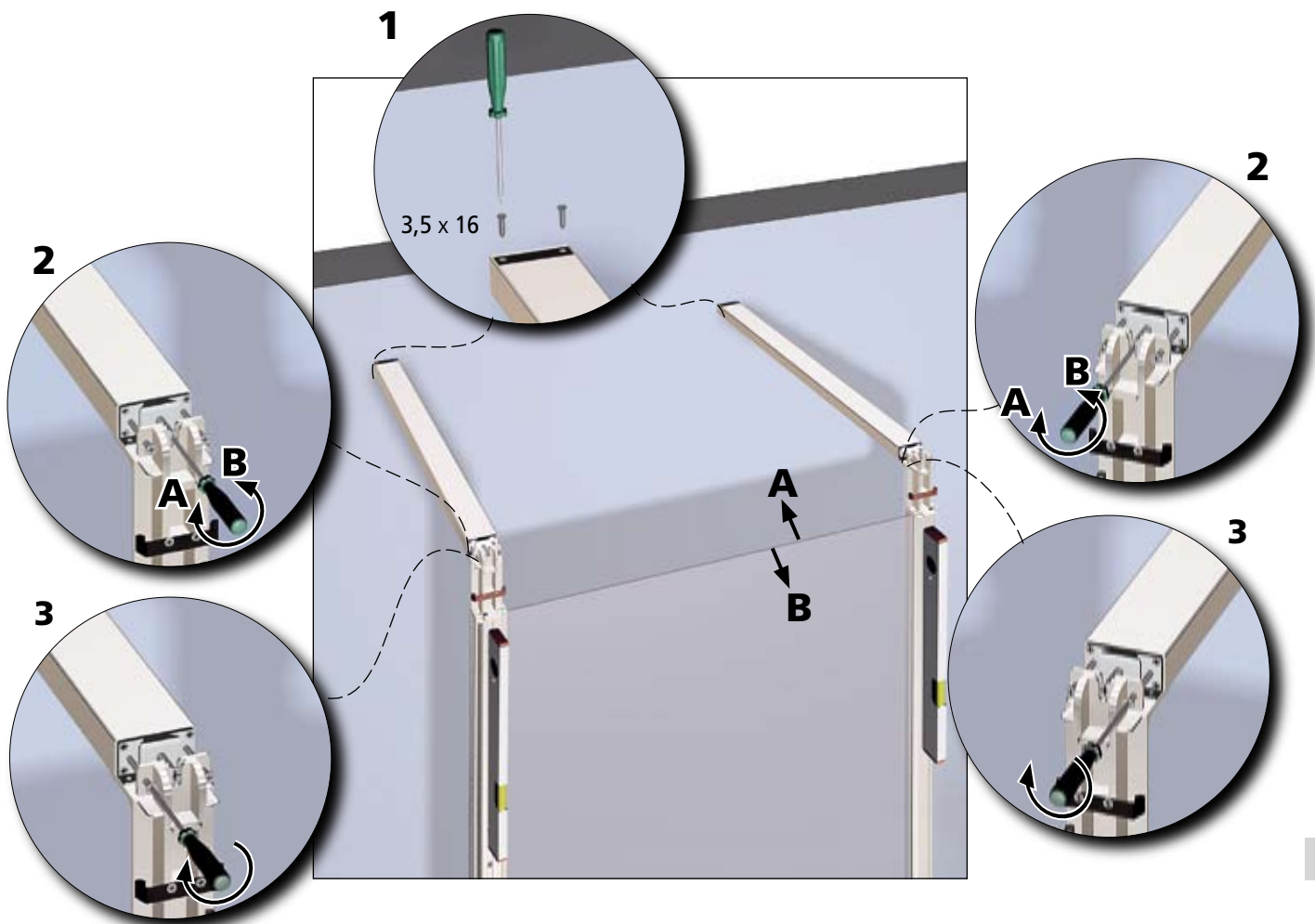

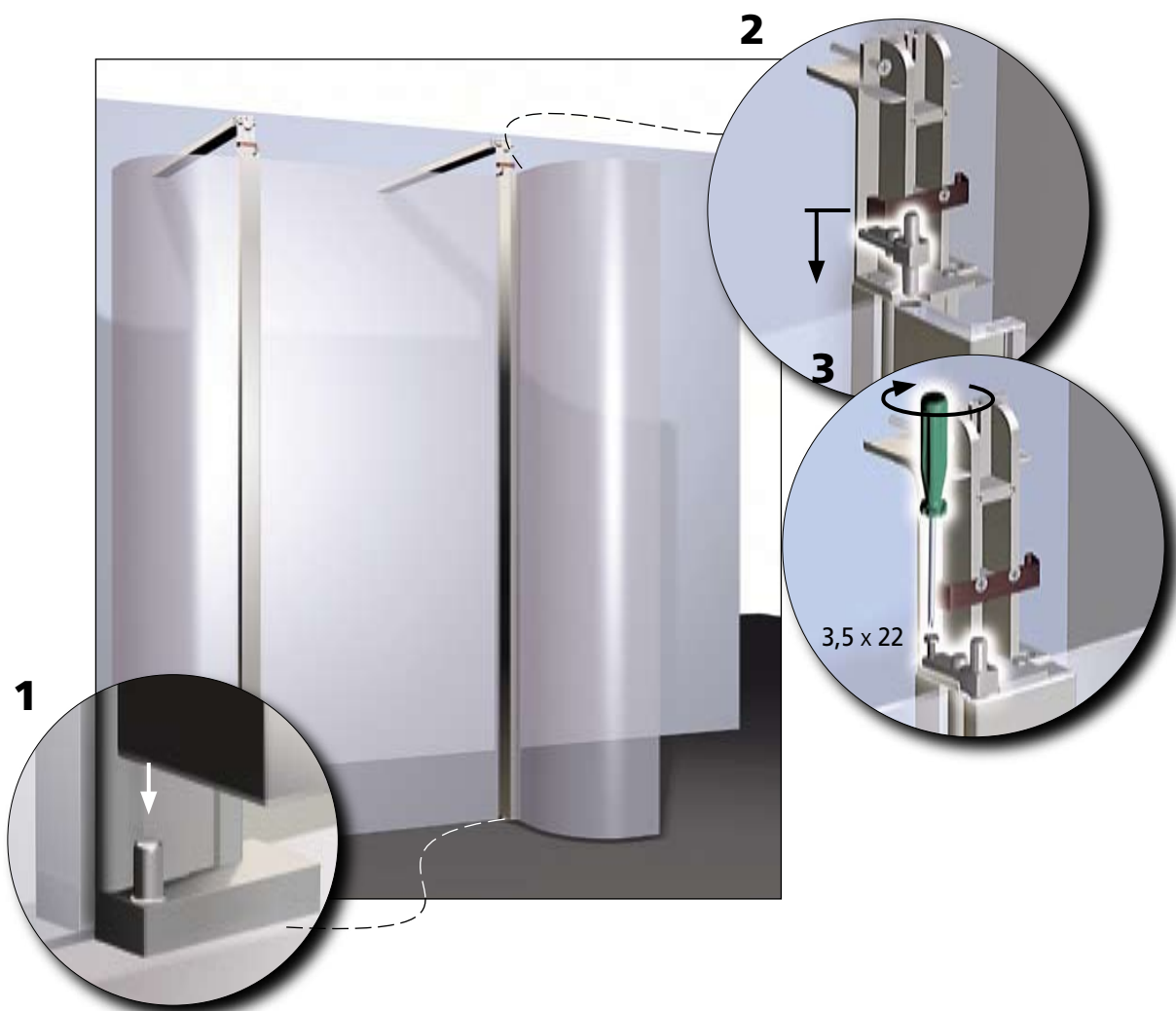
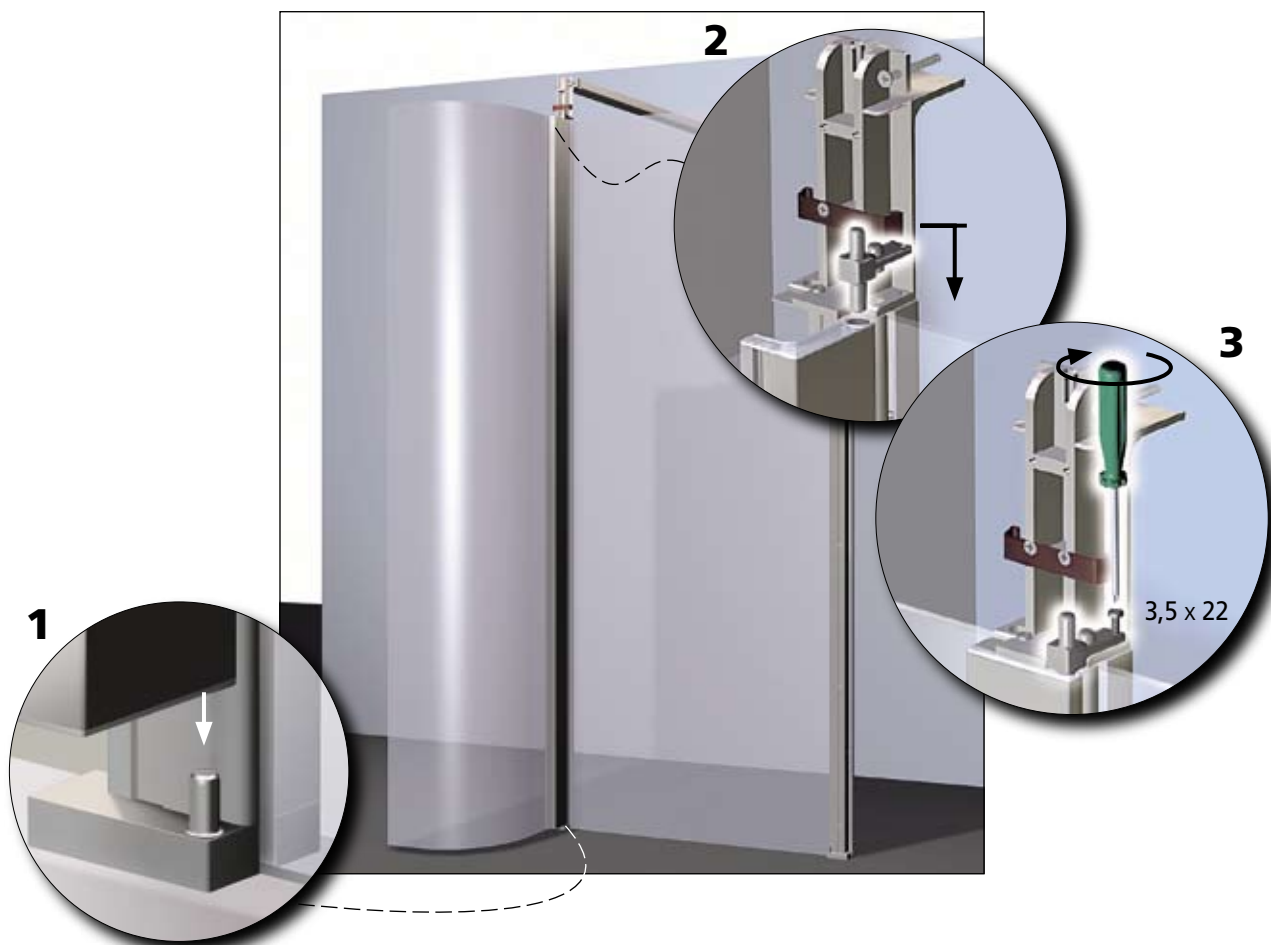

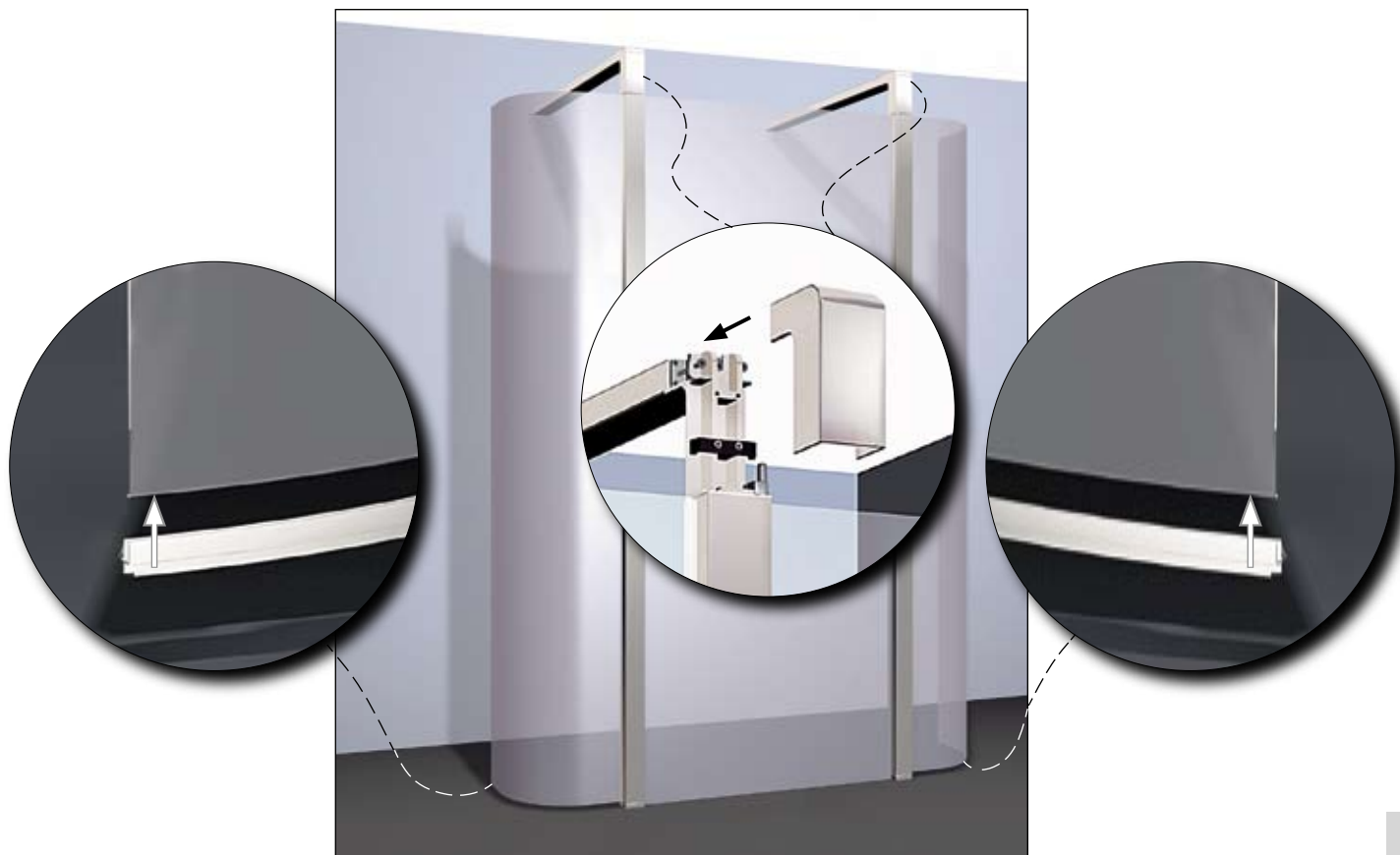

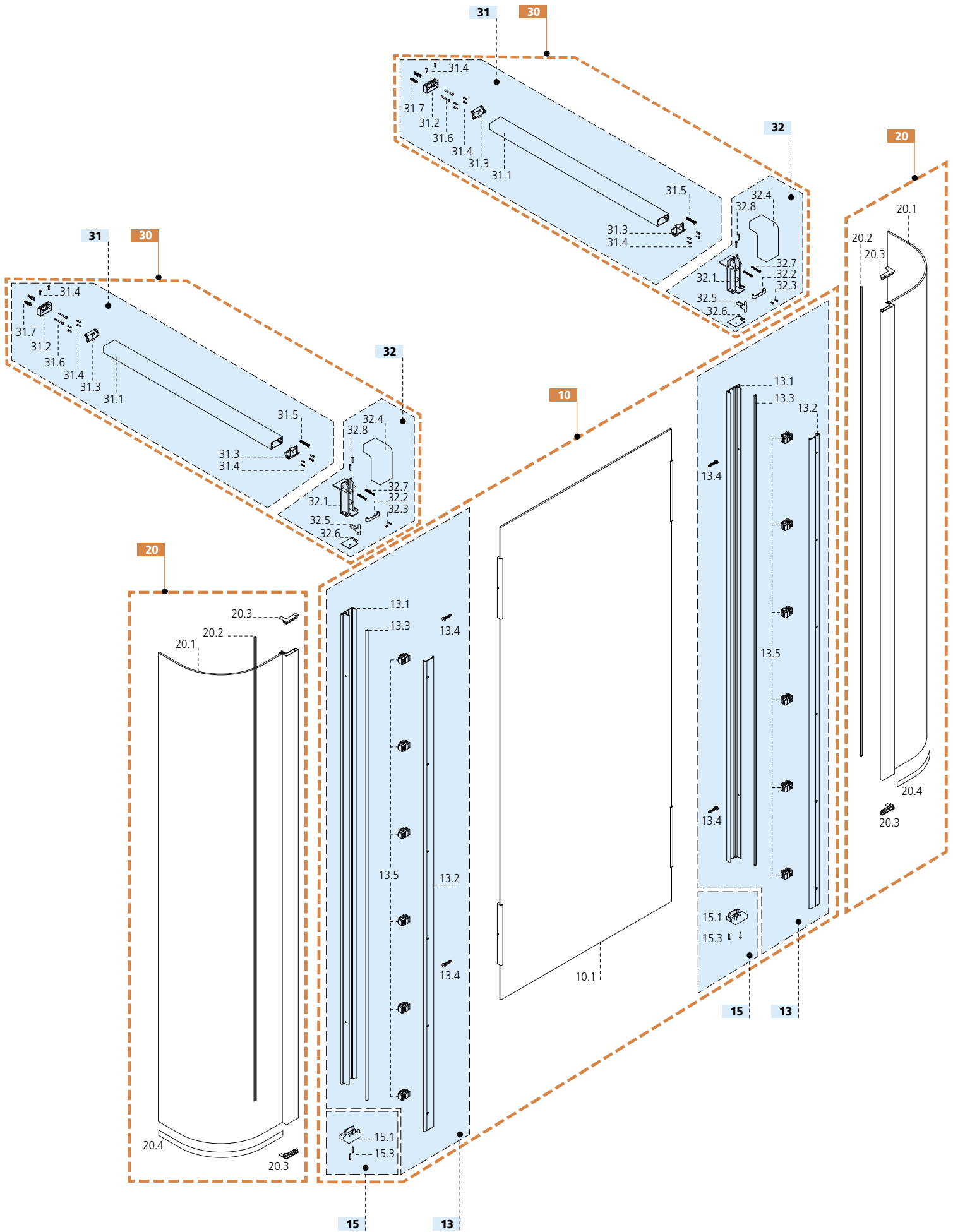

<p>D Bei Ersatzteillieferungen sind folgende Angaben erforderlich:</p>	<p>I Per ordini di pezzi di ricambio sono necessari i seguenti dati:</p>	<p>NL Bij onderdeelbestellingen zijn de volgende gegevens gewenst:</p>	<p>GB Spare parts need the following specification:</p>	<p>F Pour toute commande de pièces détachées, il est nécessaire de fournir:</p>	<p>E Para pedir los repuestos, necesitamos de los siguientes datos:</p>	<p>PL W przypadku dostaw części zamiennych wymagane są następujące dane:</p>
---	---	---	--	--	--	---

Breite	larghezza	breedte	width	largeur	anchura	szerokość
Farbe	colore	kleur	colour	couleur	color	kolor
Höhe	altezza	hoogte	hight	hauteur	altura	wysokość
Glas	vetro	glaspaneel	Glas-type	verre	vidrio	element szklany

Pos.	Art.
10	EL0002
10.1	EL0001
13	EL0019
13.1	PRHK003
13.2	PRHK004
13.3	GUMK073
13.4	KLEK041
13.5	EL0030
15	EL0021
15.1	KLEK028
15.3	SRAKF3522

Pos.	Art.
20	EL0038
20.1	EL0039
20.2	GUMK073
20.3	EL0040
20.4	GUMC192

Pos.	Art.
30	EL0016
31	EL0025
31.1	PRBK006
31.2	KLEK025
31.3	KLEK026
31.4	SRAKVA35X16
31.5	SRAM640KV
31.6	SRAKFB3938
31.7	KLE001
32	EL0026
32.1	KLEK024
32.2	KLEL132
32.3	SRAKFS3595
32.4	KLEK027
32.5	KLEK021
32.6	PLK020
32.7	SRAM440KV
32.8	SRAKF3522

Montageset



Garantieschein
Certificato di garanzia

- D** Der Produzent behält sich jederzeit das Recht, ohne Vorbescheid Abänderungen vorzunehmen.
- I** Il produttore si riserva il diritto di apportare modifiche al prodotto senza preavviso.
- NL** De producent houdt zich het recht voor, ten alle tijde zonder tegenbericht veranderingen door te voeren.
- GB** The producer reserves the right to modify the product at any time without prior notice.
- F** Le producteur se réserve le droit de modifier le produit sans aucun préavis.
- E** El productor se reserva el derecho de aportar modificaciones al producto sin previo aviso.
- PL** Producent zastrzega sobie prawo do wprowadzania zmian bez uprzedniego powiadamiania.